

MILORAD TOMIĆ^{1,2}

<https://orcid.org/0009-0004-1022-2093>

MARIJA MITROVIĆ¹

<https://orcid.org/0000-0002-3208-016X>

REGINA FUCHS-GODEC³

<https://orcid.org/0000-0002-5700-0963>

NEBOJŠA VASILJEVIĆ¹

<https://orcid.org/0000-0002-3789-9975>

DRAGAN TOŠKOVIĆ¹

<https://orcid.org/0009-0005-7544-1884>

MIOMIR PAVLOVIĆ^{1†}

¹University of East Sarajevo,
Faculty of Technology Zvornik,
Zvornik, Republic of Srpska,
Bosnia and Herzegovina

²Engineering Academy of Serbia,
Belgrade, Serbia

³University of Maribor, Faculty of
Chemistry and Chemical
Engineering, Maribor, Slovenia

SCIENTIFIC PAPER

UDC 620.193/197:669.14:544.6:582.998.14

INTRODUCTION

Corrosion of steel in acidic environments, particularly in industrial applications such as chemical processing, oil and gas exploration, and metal cleaning, remains a significant challenge due to the aggressive nature of acids like hydrochloric acid (HCl). Steel, a commonly used mate-

Correspondence: M. Mitrović, University of East Sarajevo, Faculty of Technology Zvornik, Karakaj 34A 75400 Zvornik, Republic of Srpska, Bosnia and Herzegovina.

Email: marija.ridjosic@tfzv.ues.rs.ba

† Prof. Miomir Pavlović (1953-2025), co-author of this manuscript, passed away during the review process. This paper is published in recognition of his valuable contribution.

Paper received: 22 Mart 2025

Paper revised: 26 July 2025

Paper accepted: 22 November 2025

<https://doi.org/10.2298/CICEQ250322029T>

Taraxacum officinale EXTRACT AS A GREEN ALTERNATIVE FOR CORROSION CONTROL OF STEEL IN ACIDIC ENVIRONMENT

Highlights

- This study shows the *Taraxacum officinale* root extract as a sustainable corrosion inhibitor for steel
- The TO extract inhibits corrosion up to 89%, with higher concentrations offering better protection
- Surface analysis showed a protective film on steel with the TO extract, unlike the acidic solution
- FTIR identified functional groups (C–H, C–O, C=O, O–H) in the TO extract that prevent corrosion
- Potentiodynamic and EIS tests show the TO extract as an anodic inhibitor, covering 88% of the surface

Abstract

This study investigates the potential of Taraxacum officinale (TO) root extract as an environmentally friendly corrosion inhibitor for two types of steel, TH-550 and TS-275, in an acidic environment. The corrosion inhibition was assessed by monitoring the weight loss of steel samples over a 72-hour immersion period in four different solutions: blank 4% HCl solution and 4% HCl solutions containing 0.5, 1.0, and 1.5 g/L of TO root extract. The inhibitor efficiency, calculated from weight loss data, ranged from 70% to 89%. Surface analysis of the steel samples, conducted after 24 hours of immersion, revealed the formation of a uniform protective film on the steel exposed to the inhibited solutions, while samples in the blank acidic solution showed significant corrosion. Fourier-transform infrared spectroscopy analysis identified key metal-complexing functional groups in the TO root extract, including aromatic C–H, C–O, C=O, and O–H, which are likely responsible for the interaction with the steel surface. Potentiodynamic polarization measurements indicated that the TO root extract acts as an anodic corrosion inhibitor, with the ability to cover up to 88% of the steel surface. Electrochemical impedance spectroscopy, in combination with polarization and weight loss results, demonstrated that the inhibitor efficiency of the TO root extract increases with concentration.

Keywords: corrosion, green inhibitors, environmentally friendly, dandelion root extract, electrochemistry.

rial in these environments, is highly susceptible to corrosion, leading to material degradation, increased maintenance costs, and potential failure of equipment. To mitigate these issues, various corrosion inhibitors have been developed, which typically form a protective layer on the metal surface, preventing direct contact between the metal and corrosive agents. However, many of the conventional corrosion inhibitors used in industrial applications contain toxic or hazardous chemicals, posing environmental and health risks. These drawbacks have spurred the search for more sustainable, environmentally friendly alternatives. Consequently, there has been growing interest in using natural plant extracts as corrosion inhibitors due to their non-toxic, biodegradable, and eco-friendly properties. Natural plant extracts have emerged as

promising green corrosion inhibitors [1-7]. Organic corrosion inhibitors work primarily by adsorbing onto metal surfaces, unlike inorganic inhibitors, which typically reduce corrosion by participating in anodic or cathodic reactions. Organic compounds that possess high electron density, along with heteroatoms such as phosphorus, sulfur, nitrogen, or oxygen, as well as those containing multiple bonds, are particularly effective at preventing corrosion [1,8-10]. A large proportion of organic compounds found in natural extracts feature multiple n-bonds, various functional groups (such as -OR, -COOH, -SR, and R₂), and heteroatoms (N, S, O) [4,11-13]. These inhibitor molecules can adhere to metal surfaces through strong coordination interactions between the metal and the lone pairs of electrons on the heteroatoms [14,15]. Natural inhibitors offer several advantages, including lower toxicity compared to synthetic inhibitors, as they come from renewable sources [16,17]. Additionally, plants are abundant and often more cost-effective than commercially manufactured chemicals. Numerous studies have demonstrated the effectiveness of plant extracts, either produced from leaves, flowers, or roots, in reducing corrosion in steel and other metals exposed to aggressive environments. One such promising source is the dandelion (*Taraxacum officinale*), a common plant known for its rich phytochemical composition, including flavonoids, alkaloids, and phenolic compounds. *Taraxacum officinale* (TO) is a widely available yet underexplored plant for corrosion inhibition. These bioactive molecules could interact with metal surfaces and form protective layers, reducing corrosion rates in acidic environments. While there are several studies examining the dandelion as a corrosion inhibitor in cooling systems, simulated brine solution, and NaCl [18-20], there is no information available about the influence of dandelion root extract on the corrosion of steel in 4% HCl. The 4% HCl solution is commonly used in corrosion studies involving environmentally friendly corrosion inhibitors for several reasons. 4% HCl mimics real-world conditions found in industrial processes such as acid pickling, descaling, and oil well acidizing. 4% HCl provides a controlled but aggressive environment to test inhibitor efficiency. It's strong enough to cause measurable corrosion, but not so strong that the metal dissolves too quickly, which could mask inhibitor performance. Green inhibitors (e.g., plant extracts, amino acids, biodegradable compounds) are often less potent than synthetic ones, so a moderate acid concentration like 4% HCl is ideal for evaluating their efficiency. Higher acid concentrations might overwhelm their inhibitory effect. Ugi *et al.* examined various components of dandelion leaf extract and found a maximum inhibition efficiency of 79% in diluted 0.2M HCl, obtained by electrochemical impedance spectroscopy [6]. Research on the use of the TO root extract as a corrosion inhibitor, particularly from ethanol extracts of the plant root, in conventional corrosion media like 4% HCl, is limited. The present study aims to explore the potential of the TO root extract as a green, environmentally friendly corrosion inhibitor for steel in 4% HCl solution.

Using two types of steel, TH-550 and TS-275, the inhibitor's performance will be evaluated through a combination of

weight loss measurements, electrochemical techniques (including potentiodynamic polarization and electrochemical impedance spectroscopy), surface analysis using scanning electron microscopy (SEM) coupled by energy dispersive X-ray spectroscopy (SEM-EDAX) and chemical identification and characterization by Fourier-transform infrared spectroscopy (FTIR). By examining the corrosion inhibition efficiency and understanding the mechanisms involved, this study seeks to establish the TO root extract as a viable potential alternative to conventional synthetic corrosion inhibitors, contributing to the development of more sustainable corrosion control methods in industrial applications.

EXPERIMENTAL PART

Two types of steel were used in the experiments: TH-550 (Steel 1) and TS-275 (Steel 2). The chemical composition of Steel 1 (TH-550) is as follows: 0.09 wt.% C, 0.32 wt.% Mn, 0.27 wt.% Sb, 0.02 wt.% Si, 0.11 wt.% Sn, 0.01 wt.% P, with the balance being Fe up to 100%. The chemical composition of Steel 2 (TS-275) is: 0.10 wt.% C, 0.29 wt.% Mn, 0.02 wt.% Si, 0.01 wt.% P, with the balance being Fe up to 100%. TO root extract was obtained through Soxhlet extraction using 96% ethyl alcohol as the solvent (200 mL). The extraction process was carried out in a Soxhlet apparatus with 10 g of solid plant material, specifically TO root. The inhibitory effect of the TO root extract on steel corrosion was evaluated using three techniques: weight loss measurements, potentiodynamic polarization, and electrochemical impedance spectroscopy (EIS). All tests were conducted in both blank and inhibited 4% HCl solutions at room temperature. Prior to each experiment, the steel samples were degreased, etched in 20% H₂SO₄ for 1 min at 65 °C, rinsed with ethanol, and dried. The samples were then immersed in either blank 4% HCl or 4% HCl containing 0.5, 1, and 1.5 g/L TO root extract, for 2, 4, 6, 24, 48, and 72 h. The experiments were performed in triplicate, and average values were used for calculation. Based on the weight loss in steel samples for the time spent in prepared solutions, the negative mass index of corrosion, K_m^- , corrosion rate, π , and corrosion inhibition efficiency η_{ML} were calculated.

The negative mass index of corrosion, K_m^- [g/m²h] was calculated by Eq. (1) [20,21]:

$$K_m^- = \frac{m_{before} - m_{after}}{S_s \cdot t} \quad (1)$$

where m_{before} and m_{after} are the samples' masses before and after the determined immersion time in blank and inhibited solutions, S_s is the steel sample area in m², and t is the immersion time in h.

The corrosion rate, π [mm/year], was determined by Eq. (2) [20,21]:

$$\pi = \frac{K_m^- \cdot 8.76}{d} \quad (2)$$

where d is the steel density [g/cm³], and 8.76 is the number of hours in one year divided by 1000.

The corrosion inhibition efficiency, η_{ML} (%), was evaluated by Eq. (3) [20,21]:

$$\eta_{ML} = \frac{K_{m,0}^- - K_m^-}{K_{m,0}^-} \cdot 100 \quad (3)$$

where $K_{m,0}^-$ is the negative mass index of corrosion in blank 4% HCl.

The efficiency of the TO root extract as a corrosion inhibitor and corrosion mechanism was investigated by potentiodynamic polarization resistance and EIS using a potentiostat/galvanostat/ZRA Gamry Series GTM 750, in a three-electrode cell. The saturated calomel electrode was used as a reference electrode, a Pt electrode was used as a counter electrode, and a tested steel sample with a surface area of 1 cm² was the working electrode. The polarization plots were recorded in the range of ± 0.25 V with respect to the open circuit potential, with a recording speed of 1 mV/s. The electrochemical impedance spectroscopy frequency range was 100kHz - 10 mHz, with a 7 mV sinusoidal voltage amplitude, at open circuit potential. The corrosion current density, corrosion potential, corrosion rate, and cathodic and anodic slope were obtained by DC Corrosion Software for ZRA Gamry Series GTM 750 potentiostat/galvanostat.

The polarization resistance, R_p (Ω cm²), is calculated according to the Stern-Geary equation [20]:

$$R_p = \frac{\beta_a \cdot \beta_c}{2,3 j_{corr} (\beta_c + \beta_a)} \quad (4)$$

where β_a and β_c are the anodic and cathodic polarization slopes in V, j_{corr} is the corrosion current density in A/cm².

Steel surface coverage by inhibitor molecules was calculated by Eq. (5) [22]:

$$\theta = \frac{j_{corr,0} - j_{corr}}{j_{corr,0}} \quad (5)$$

where $j_{corr,0}$ is the corrosion current density of steel in blank HCl, and j_{corr} is the corrosion current density of steel in inhibited HCl solution.

The inhibitor efficiency η (%) was also calculated: based on gained total polarization resistance of steel in the inhibited (R_{sum}) and blank HCl solution ($R_{sum,0}$), according to Eq. (6) [20]:

$$\eta = \frac{R_{sum} - R_{sum,0}}{R_{sum}} \cdot 100 \quad (6)$$

The steel surface morphology and composition after 24 h in a blank and inhibited acidic solution were examined by SEM and energy dispersive X-ray spectroscopy using ZEISS EVO 10 microscopy. The characteristics of the inhibitor film formed on the steel after immersion in the inhibited solution for 24 h were studied by ATR-FTIR spectra. The IR spectra were recorded with a spectral resolution of 4 cm⁻¹ and in a wavenumber range of 400-4000 cm⁻¹.

RESULTS AND DISCUSSION

Weight loss results

Figure 1 illustrates the relationship between the steel corrosion rate and corrosion inhibition efficiency values of steel 1 and 2 and time in blank and inhibited 4% HCl

solutions, based on the weight loss method.

From Figure 1(a), it is evident that the values of the corrosion rate show a significant decrease when inhibited solutions were used. The highest corrosion rates for S1 were observed in blank 4% HCl, with values ranging from 0.83 to 0.87 mm/year across all immersion time intervals. In contrast, there is a noticeable decrease in the corrosion rate for inhibited solutions after just 2 hours, and these values remain relatively stable throughout the remaining test period (up to 48 hours). Specifically, across all tested durations (2, 4, 6, 24, 48, and 72 hours), the corrosion rate of steel type 1 decreases markedly with increasing concentrations of TO root extract in 4% HCl solution. The corrosion rates for solution 2 (4% HCl + 0.5 g/L TO root extract) range from 0.27 to 0.30 mm/year, for solution 3 (4% HCl + 1.0 g/L TO root extract) from 0.22 to 0.24 mm/year, and for solution 4 (4% HCl + 1.5 g/L TO root extract) from 0.10 to 0.18 mm/year. These results clearly demonstrate the dose-dependent efficacy of the TO root extract in significantly mitigating the corrosion rate of steel 1 in acidic environments. From Figure 1(b), a similar corrosion inhibition trend is observed for steel type S2, demonstrating a consistent time-dependent decrease in corrosion rate across all inhibited solutions. The lowest corrosion rate is recorded in solution 4 (4% HCl + 1.5 g/L TO root extract) after 2 hours, with a value of 0.06 mm/year. Notably, corrosion rate values stabilize after 6 hours of immersion in the inhibited solutions, indicating the formation of a passivating protective layer on the steel surface. Furthermore, corrosion rates measured at 24, 48, and 72 hours show minimal variation and closely converge, underscoring the durability of the inhibition effect over extended periods. Overall, the data confirm a clear inverse correlation between TO root extract concentration and corrosion rate, reinforcing the extract's efficacy in significantly retarding the corrosion process. From Figures 1c and 1d, it is evident that the inclusion of TO root extract in 4% HCl imparts a significant protective effect on both steel types S1 and S2. The highest corrosion inhibition efficiency, reaching 88.89%, is observed at the maximum TO root extract concentration of 1.5 g/L after 2 hours of immersion. Moreover, this pronounced inhibitory effect remains stable and consistent across all exposure durations, demonstrating the sustained efficacy of the TO root extract in mitigating corrosion over time.

The lowest protection efficiency of 65.82% was observed at a TO root extract concentration of 0.5 g/L after 72 hours of exposure. Figures 1(c) and 1d clearly demonstrate that corrosion inhibition efficiency increases with rising concentrations of TO root extract. The TO root extract acts as an effective corrosion inhibitor in 4% HCl at all tested concentrations, with inhibition efficiencies ranging from 65.82% to 88.89%. Notably, solution 4, containing 1.5 g/L of TO root extract, provides the highest level of protection, with inhibition efficiencies between 78.89% and 88.89%, depending on immersion duration.

Figure 1(d) illustrates that at TO root extract concentrations of 0.5 and 1.0 g/L, the protection efficiency for steel type S2 does not exceed 50% at any tested

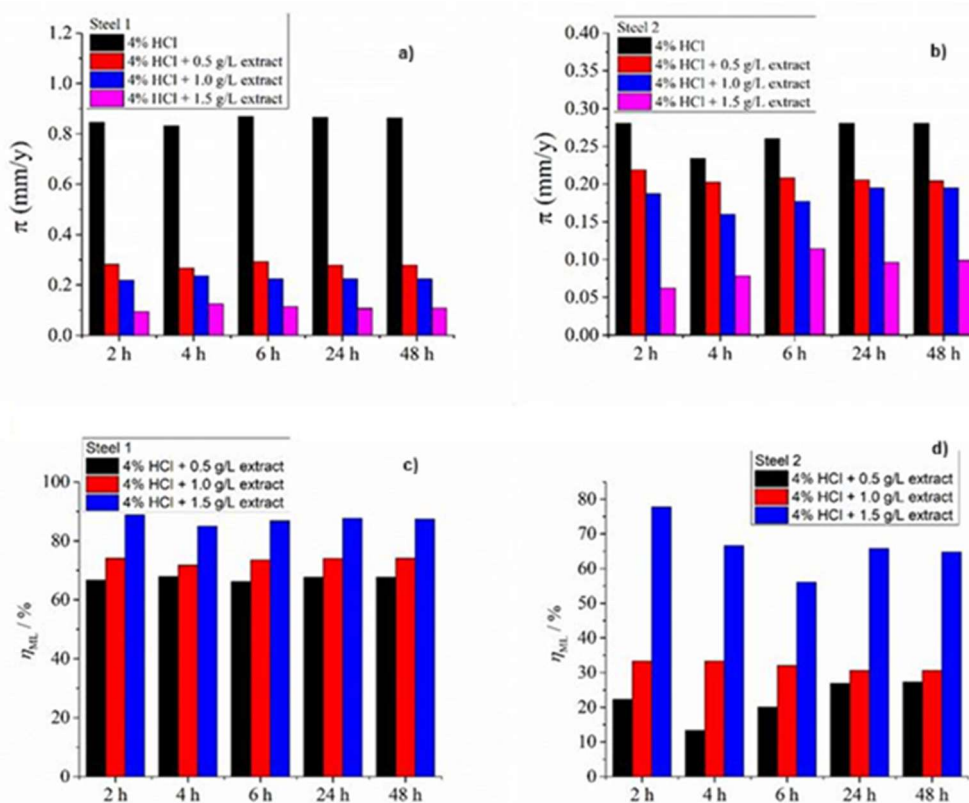

Figure 1. Corrosion rate values for (a) steel 1 and (b) steel 2, and corrosion inhibition efficiency values for (c) steel 1 and (d) steel 2 in blank and inhibited 4% HCl with 0.5, 1.0, and 1.5 g/L TO root extract.

duration, indicating limited inhibition performance at these levels. In contrast, at the higher concentration of 1.5 g/L (solution 4), the corrosion inhibition efficiency for S2 improves significantly, ranging from 56.01% to 77.77%, which reflects markedly enhanced inhibitory properties. Notably, the TO root extract demonstrates significantly higher corrosion inhibition efficiency for steel type S1 under identical conditions, with efficiency values ranging from 78.89% to 88.89% in solution 4. These findings clearly illustrate that different steel grades exhibit distinct corrosion behaviors even when exposed to the same corrosive environment. This variability emphatically highlights the critical necessity of material-specific corrosion evaluation prior to the selection of steel for construction and industrial applications. Furthermore, weight loss measurements confirm that the two investigated steel types respond differently to 4% HCl in the presence of 1.5 g/L TO root extract compared to the uninhibited blank solution, reinforcing the importance of tailored corrosion mitigation strategies.

Surface morphology and FTIR spectra

To further investigate the behavior of steel in blank and inhibited HCl solution, the morphology of both steel types was analyzed using SEM. The results shown in Figure 1 confirmed that both steel types underwent passivation in the inhibited solutions, which reduced the corrosion rate and suggested the formation of a protective film composed of phytochemicals from the TO root extract. SEM micrographs of steel samples after 24 hours of immersion in both the blank and 4% HCl inhibited with 1.5 g/L TO root

extract are shown in Figure 2. As seen in Figures 2(a) and 2c, the bare steel surface was highly heterogeneous after 24 hours in HCl, indicating active corrosion and deterioration of the steel properties. However, when 1.5 g/L of TO root extract was added to the 4% HCl, the steel surface appeared much more homogeneous after 24 hours, suggesting the protective effect of the extract. This improved surface uniformity supports the hypothesis that the extract forms a protective layer on the steel. The phytochemicals in the TO root extract may interact with active sites on the steel surface, forming this protective film through various mechanisms: physisorption (weak van der Waals forces attracting plant extract molecules to the metal), chemisorption (stronger chemical bonds between the plant molecules and the metal, leading to a more stable protective layer), and retrodonation (electron donation from the plant molecules to the metal, reducing its reactivity and corrosion susceptibility) [9]. Additionally, according to EDAX results, the carbon and oxygen content on the steel surface after 24 hours of exposure to the inhibited solutions was significantly higher compared to that of the bare steel, confirming the adsorption of organic compounds derived from the plant extract. These findings further support the conclusion that the TO root extract facilitates the formation of a protective organic film on the steel surface.

Surface analyses confirm the presence of an organic protective film on the steel surface. However, these techniques do not provide conclusive information regarding the specific classes of organic compounds adsorbed onto the steel. According to Jedrejek *et al.* [23], more than 100

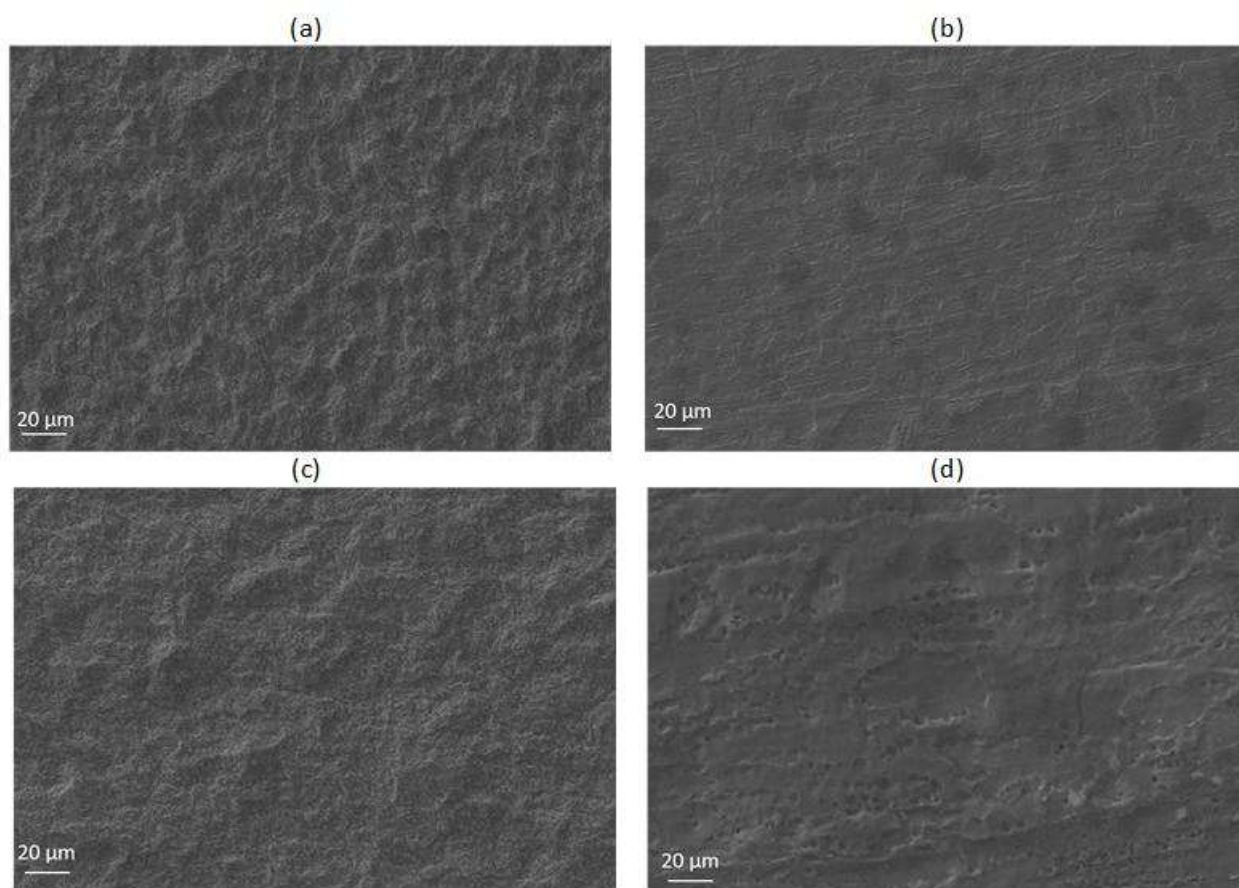

Figure 2. SEM micrographs of Steel 1 surface after 24 h in a) 4% HCl, b) 4% HCl + 1.5 g/L TO root extract, and Steel 2 surface after 24 h in c) 4% HCl, d) 4% HCl + 1.5 g/L TO root extract.

compounds are present in dandelion root extract. These compounds were classified into three major groups of secondary metabolites: hydroxycinnamic acid (HCA) derivatives, hydroxyphenylacetic acid (HPA) derivatives, and sesquiterpene lactone (SL) derivatives. Among these, HCA esters were the most abundant, comprising 42 compounds, followed closely by 39 HPA derivatives. Additionally, 20 compounds were identified as SLs, while 11 minor compounds remained unidentified and could not be classified [23]. Thus, TO root extract is rich in a range of bioactive compounds, including phenolic compounds, terpenes, sesquiterpene lactones, fructans, and inulin. Inulin, which can comprise up to 40% of the extract, is known for its ability to adsorb metal ions [24]. Additionally, aromatic compounds, particularly those containing heteroatoms, are recognized for their reactivity with metal surfaces [4]. To gain a more detailed understanding of the active phytochemicals from the TO root extract that contribute to the suppression of steel corrosion in an acidic environment, FTIR spectroscopy was employed. The FTIR spectra of steel types 1 and 2 after 24 hours of immersion in 4% HCl inhibited with 1.5 g/L TO root extract are presented in Figure 3. The IR bands observed at 620 cm^{-1} , 1043 cm^{-1} , 1634 cm^{-1} , and 3310 cm^{-1} correspond to the bending vibrations of aromatic C–H, the C–O stretching, C=O stretching, and O–H vibrations, respectively. These groups interact with the steel surface by electrostatic attraction (physisorption) between charged inhibitor

molecules and the positively charged steel surface and by chemical bonding via electron donation from heteroatoms to the d-orbitals of Fe atoms on the surface. Once adsorbed, the TO root extract molecules form a compact, adherent organic layer on the steel surface. This layer blocks active corrosion sites, especially anodic (metal dissolution) and cathodic (hydrogen evolution) regions, and acts as a physical barrier, preventing direct contact between the metal surface and aggressive Cl^- and H^+ ions from HCl.

Potentiodynamic polarization and EIS results

Figures 4(a) and (b) depict potentiodynamic polarization plots showing the dependence between potential (E) and the logarithm of current density ($\log j$) in a 4% HCl solution with different inhibitor concentrations for steels S1 and S2. The relevant electrochemical parameters were derived from the polarization plots, including corrosion potential (E_{corr}), corrosion current density (j_{corr}), cathodic slope (β_c), and anodic slope (β_a). They are shown in Table 1 along with the calculated polarization resistance (R_p) and surface coverage (θ).

Based on the results shown in Figures 4(a) and (b) and Table 1, it is clear that the TO root extract reduces the corrosion rate for both steel types in an acidic environment. A significant reduction in the corrosion current is observed for steel S1 in inhibited solutions, which is also confirmed by weight loss results. As the concentration of TO root

extract increases, the corrosion current density, and consequently the corrosion rate, decrease while polarization resistance values increase. For steel S2, the corrosion current density in the uninhibited solution is notably lower than for steel S1, indicating that the primary composition and possibly the different heat treatments (hardening, annealing, tempering) of the steel have a substantial impact on its corrosion behavior in an acidic environment. Similar to S1, as the concentration of the TO root extract increases, the corrosion current density and corrosion rate for steel S2 also decrease. From the polarization plots shown in Figures 4(a) and (b), it is evident that the cathodic branches for both steels are parallel to that of the uninhibited solution, indicating that the addition of TO root extract does not alter the hydrogen evolution mechanism. However, the corrosion potential shifts to a more anodic region when the extract is added to the acidic solution. The mechanism of TO root extract inhibition is based on blocking the anodic reactions and, subsequently, lowering of the current density during anodic scan. The extract molecules adsorb onto the steel surface through functional groups such as aromatic C–H, C–O, C=O, and O–H, thereby blocking active reaction sites and reducing the surface area available for H⁺ ion interaction. While the overall mechanism of hydrogen evolution remains unchanged, the protective film formed by the adsorbed phytochemicals from the extract contributes to corrosion inhibition. The calculated surface coverage of steel by inhibitor molecules increases with the concentration of the inhibitor in the acidic solution. As shown in Table 1, a greater proportion of steel S1's surface is covered by the inhibitor molecules compared to steel S2. This observation is further supported by SEM analysis, where the surface of steel S1 appears uniform after 24 hours in the inhibited solution, while agglomerated clusters are visible on the surface of steel S2, indicating incomplete coverage (Figure 2).

To further analyze the electrochemical behavior of steel in both blank and inhibited acid solutions, EIS was employed. The Nyquist plots for steel S1 and S2 in the

examined solutions are shown in Figure 5, while the Bode plots are presented in Figure 6(a) and (b).

The Nyquist plots for all steel samples exhibit depressed semicircles, indicating non-ideal capacitive behavior. The radius of the capacitive loops at low frequency is larger in the presence of 1.5 g/L TO root extract compared to the other inhibitor concentrations, indicating a reduction in the corrosion rate. The Nyquist plot at full impedance range shows that the performance of 0.5 g/L TO root extract in corrosion protection of steel 2 is not significant. The value of the impedance modulus in the low-frequency range shows a significant change in the presence of TO root extract. The addition of 1.5 g/L increased the impedance modulus value by about 4 times compared to values in blank acid solutions. This increase indicates that the extract inhibits both oxidation and reduction processes, and the formation of a passive layer creates a repulsive effect against chloride ions, thereby limiting their access to the steel surface.

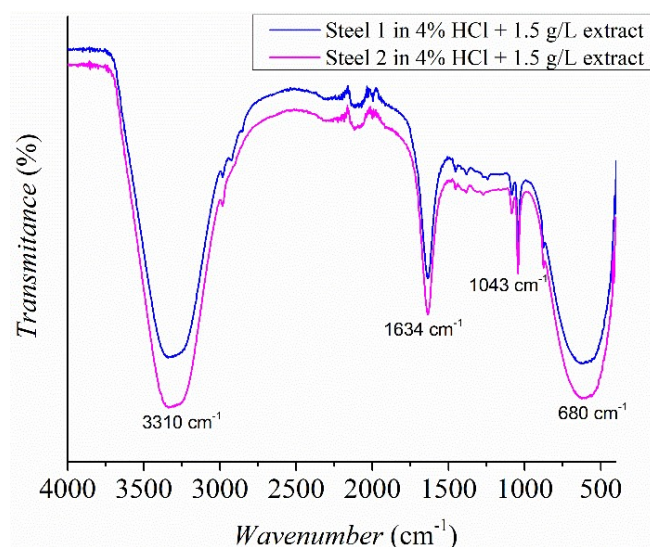

Figure 3. FTIR spectra of steel 1 and steel 2 after 24 h in 4% HCl+1.5 g/L TO root extract solutions.

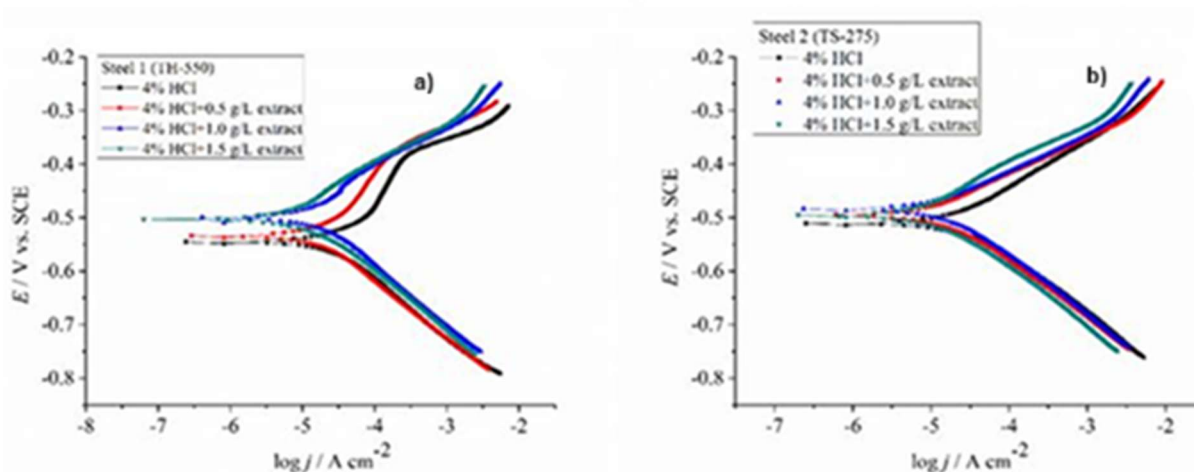

Figure 4. Potentiodynamic polarization plots for a) steel 1 and b) steel 2 in blank 4% HCl solutions and 4% HCl inhibited with 0.5, 1.0, and 1.5 g/L TO root extract.

Table 1 Calculated values of corrosion current density, corrosion potential, anodic and cathodic slope, corrosion rate, polarization resistance, and surface coverage for steel S1 and S2.

4% HCl	j_{corr} ($\mu A / cm^2$)	E_{corr} (mV)	β_a (mV/dec)	β_c (mV/dec)	π (mm/god)	R_p (Ωcm^2)	θ
Bare steel 1 surface	25.7	-546	138.9	78.35	0.87	847.5	-
+ 0.5 g/L TO root extract	8.3	-534	76.25	65.50	0.28	1845.7	0.68
+ 1.0 g/L TO root extract	6.2	-499	64.82	73.38	0.21	2416.6	0.76
+ 1.5 g/L TO root extract	3.0	-503	61.47	55.13	0.10	4212.1	0.88
Bare steel 2 surface	7.8	-510	53.62	51.00	0.26	1457.0	-
+ 0.5 g/L TO root extract	5.7	-494	57.20	64.83	0.19	2398.4	0.27
+ 1.0 g/L TO root extract	5.3	-483	51.76	52.95	0.17	2147.2	0.32
+ 1.5 g/L TO root extract	2.7	-495	43.31	43.65	0.08	3501.2	0.65

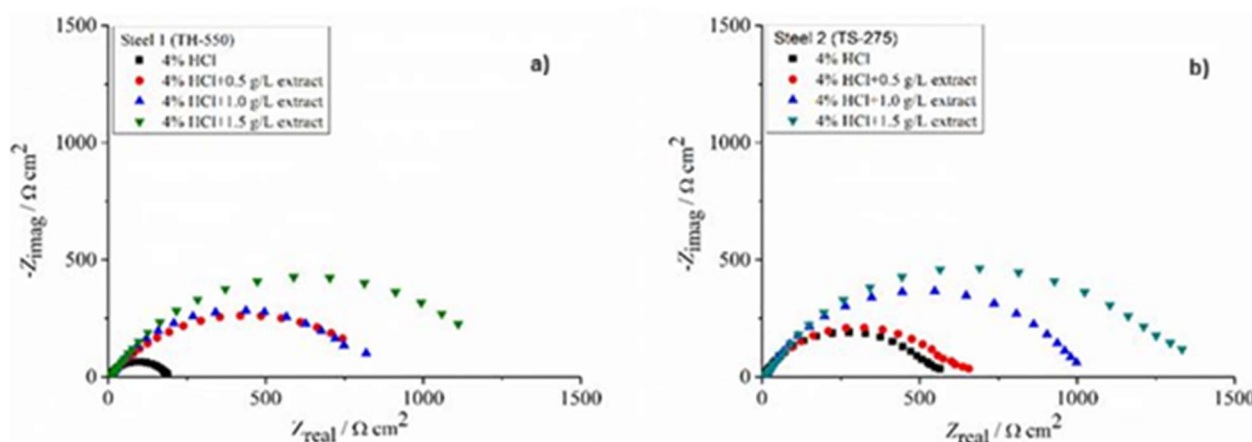

Figure 5. Nyquist plots for a) steel 1 and b) steel 2 in blank 4% HCl solutions and 4% HCl inhibited with 0.5, 1.0, and 1.5 g/L TO root extract.

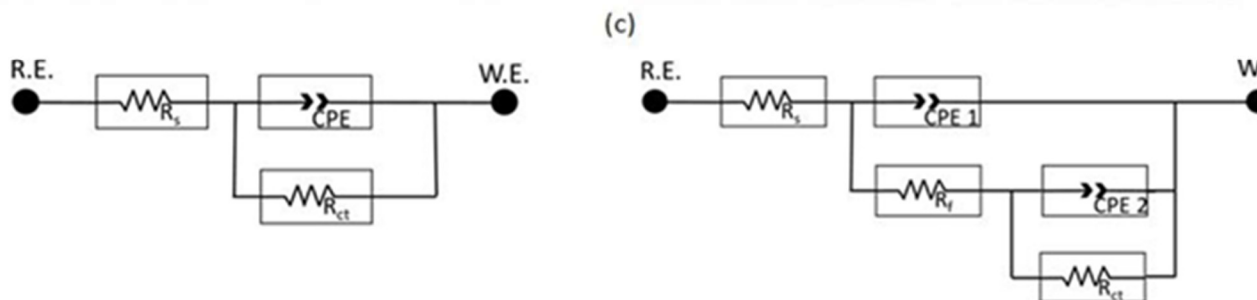
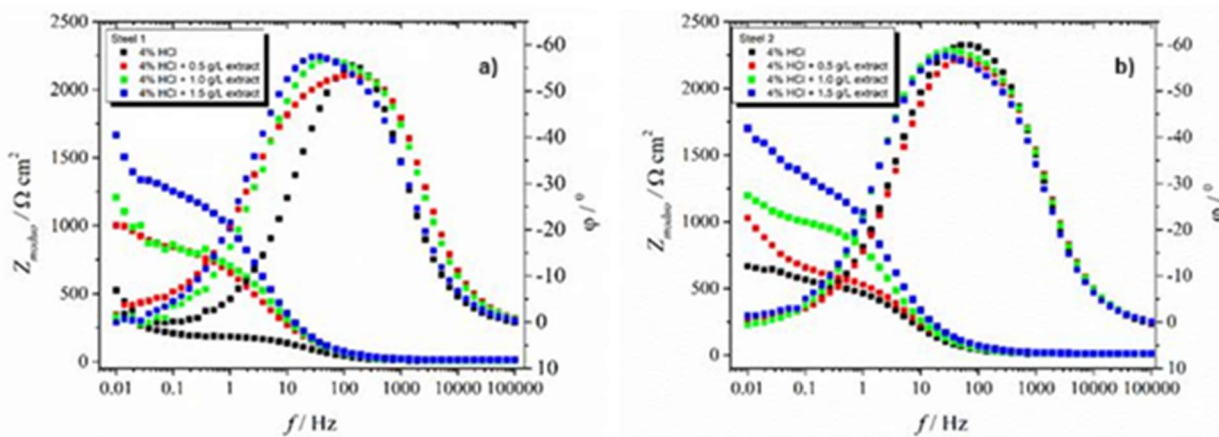

Figure 6. Bode plots for a) steel 1 and b) steel 2 in blank 4% HCl solutions and 4% HCl inhibited with 0.5, 1.0, and 1.5 g/L TO root extract, and c) equivalent electric circuits used for fitting the electrochemical impedance data.

The behavior of reinforcing steel in acidic solution at high frequencies, both with and without inhibitors, does not show significant changes in phase angle. However, the effect of the inhibitors becomes evident in the low-frequency range. At intermediate frequencies, the inhibitors altered the width of the time constant, providing insights into their performance. For steel S1, the TO root extract at a concentration of 1.5 g/L shifted the time constant toward more negative angles at middle frequencies, indicating improved capacitive properties [25]. However, this effect was not sustained at lower frequencies, where the behavior of the steel resembled that in the uninhibited acidic solution.

The obtained EIS results were fitted using the equivalent electrical circuits (EEC) shown in Figure 6(c). In an ideal capacitor, the slope of the medium-frequency Bode plot should be -1. However, for the inhibited solutions, the observed slope values range from 0.7 to 0.9, as shown in Table 2. This deviation from the ideal value suggests a departure from ideal capacitive behavior, likely due to the surface heterogeneity of the metal. The variation in slope indicates that the metal surface is not uniform, as confirmed by SEM analyses, leading to altered dielectric properties and non-ideal capacitive response. Thus, a constant phase element is utilized instead of capacitance in the proposed EEC. The R_s denotes the solution resistance, R_f is the resistance of the protective layer formed on the surface, CPE1 is the constant phase element corresponding to

capacitance of the layer, and CPE2 denotes the constant phase element corresponding to the double layer capacitance in parallel with the charge transfer resistance (R_{ct}). The obtained data are summarized in Table 2. The sum of R_f and R_{ct} gives the total polarization resistance (R_{sum}) of steel in the examined conditions. The total polarization resistance increases with increasing inhibitor concentration, as evidenced by the data presented in Table 2. At higher inhibitor concentrations, the surface of the steel is increasingly populated with inhibitor molecules, leading to an enhancement in polarization resistance. This is attributed to the formation of an inhibitor film that serves to protect the metal surface from corrosion in acidic solutions. Additionally, the observed decrease in capacitance values with increasing inhibitor concentration suggests a greater degree of surface coverage by the inhibitor molecules at the metal/solution interface, as further supported by the data presented in Table 1. Although S1 exhibited lower corrosion resistance in the blank acidic environment compared to S2, the addition of TO root extract made the corrosion resistance of steel S1 almost identical to that of S2, due to more uniform surface coverage by active compounds. The inhibitor efficiency ranged from 80 to 89% for S1 and 46 to 66% for S2, which indicates that the examined inhibitor may not provide sufficient protection for long-term use.

Table 2. Equivalent circuit parameters for the steel 1 and steel 2 electrodes in the corrosive 3% NaCl solution in the presence and absence of inhibitors.

4% HCl	$R_s \Omega \text{ cm}^2$	$R_{sum} \Omega \text{ cm}^2$	$C_p \mu\text{F}/\text{cm}^2$	n_1	$C_{dl} \mu\text{F}/\text{cm}^2$	n_2	$\eta_{EIS} (\%)$
Bare steel 1 surface	6.47	181.40	-	-	0.15	0.89	-
+ 0.5 g/L TO root extract	8.30	929.90	0.10	0.79	0.09	0.92	80.49
+ 1.0 g/L TO root extract	8.18	1176.5	0.07	0.99	0.08	0.75	84.58
+ 1.5 g/L TO root extract	8.43	1681.9	0.08	0.99	0.02	0.76	89.21
Bare steel 2 surface	6.25	595.52	-	-	0.11	0.95	-
+ 0.5 g/L TO root extract	7.76	1100.3	0.09	0.65	0.99	0.78	45.87
+ 1.0 g/L TO root extract	8.22	1250.1	0.05	0.75	0.04	0.88	52.36
+ 1.5 g/L TO root extract	8.08	1750.6	0.03	0.83	0.03	0.76	65.98

CONCLUSION

The study investigated the use of the TO root extract as an environmentally friendly corrosion inhibitor for two types of steel, TH-550 and TS-275, in an acidic environment. Corrosion was assessed by measuring the weight loss of steel samples after 48 hours of immersion in 4% HCl solutions with varying concentrations of TO root extract (0.5, 1.0, and 1.5 g/L). The corrosion rate decreased significantly with higher concentrations of TO root extract, with the corrosion rate for steel 1 dropping from 0.8676 mm/year (blank HCl) to 0.094 mm/year (1.5 g/L TO root

extract), and for steel 2 from 0.257 mm/year to 0.0624 mm/year. The protection factor ranged from 66.27% to 88.89% for steel 1 and from 56.01% to 77.77% for steel 2, depending on the inhibitor concentration. Surface analysis showed the formation of a protective film on steel exposed to the inhibited solutions, while the blank solution caused significant corrosion. FTIR spectroscopy identified key functional groups in the TO root extract, including aromatic C-H, C-O, C=O, O-H, which are responsible for the interaction with the steel surface. Electrochemical tests indicated that TO acts as an anodic corrosion inhibitor, with efficiency ranging from 46% to 89%.

ACKNOWLEDGEMENT

The Ministry of Civil Affairs of Bosnia and Herzegovina (Grant No. VM 05-07-1-3483-34/23) and the Ministry of Scientific and Technological Development and Higher Education of the Republic of Srpska (Grant No. 19.032/961-88/24) are gratefully acknowledged for supporting and funding this research.

REFERENCES

- [1] A. Dehghani, P. Ghahremani, A.H. Mostafatabar, B. Ramezanzadeh, *Biomass. Convers. Biorefin.* 14 (2024) 7467-7486. <https://doi.org/10.1007/s13399-022-02893-4>.
- [2] N.O. Eddy, U.J. Ibok, R. Garg, R. Garg, A. Iqbal, M. Amin, F. Mustafa, M. Egilmez, A.M. Galal, *Molecules* 27 (2022) 1-18. <https://doi.org/10.3390/molecules27092991>.
- [3] J. Kaur, N. Daksh, A. Saxena, *Arab. J. Sci. Eng.* 47 (2022) 57-74. <https://doi.org/10.1007/s13369-021-05699-0>.
- [4] A. Salcı, H. Yüksel, R. Solmaz, *J. Taiwan Inst. Chem. Eng.* 134 (2022) 104349. <https://doi.org/10.1016/j.jtice.2022.104349>.
- [5] Y. Wu, L. Zeng, Y. Zheng, F. You, X. Liu, *Appl. Surf. Sci.* 687 (2025) 162245. <https://doi.org/10.1016/j.apsusc.2024.162245>.
- [6] B.U. Ugi, M.E. Obeten, T.O. Magu, *Int. J. Chem. Sci.* 2 (2018) 35-43. https://www.researchgate.net/profile/Obeten-Mbang/publication/330982497_Phytochemical_constituents_of_Taraxacum_officinale_leaves_as_eco-friendly_and_nontoxic_organic_inhibitors_for_stainless_steel_corrosion_in_02_M_HCl_acid_medium/link/s/5c5e7a4c92851c48a9c4936d/Phytochemical-constituents-of-Taraxacum-officinale-leaves-as-eco-friendly-and-nontoxic-organic-inhibitors-for-stainless-steel-corrosion-in-02-M-HCl-acid-medium.pdf.
- [7] H. Parangusan, M.H. Sliem, A.M. Abdullah, M. Elhaddad, N. Al-Thani, J. Bhadra, *Int. J. Electrochem. Sci.* 20 (2025) 100919. <https://doi.org/10.1016/j.ijoes.2024.100919>.
- [8] A. Oulabbas, S. Abderrahmane, A. Salcı, İ.H. Geçibesler, R. Solmaz, *ChemistrySelect* 7 (2022) 202200212. <https://doi.org/10.1002/slct.202200212>.
- [9] N. Bhardwaj, P. Sharma, V. Kumar, *Corros. Rev.* 39 (2021) 27-41. <https://doi.org/10.1515/corrrev-2020-0046>.
- [10] G.K. Barboza, M.C. de Oliveira, M.A. Neves, A. Echevarria, *Green Chem. Lett. Rev.* 17 (2024) 2320254. <https://doi.org/10.1080/17518253.2024.2320254>.
- [11] O. Kenny, T. Smyth, D. Walsh, C. Kelleher, C. Hewage, N.P. Brunton, *Food Chem.* 161 (2014) 79-86. <https://doi.org/10.1016/j.foodchem.2014.03.126>.
- [12] A. Ostovari, S. Hoseinieh, M. Peikari, S. Shadzadeh, S. Hashemi, *Corr. Sci.* 51 (2009) 1935-1949. <https://doi.org/10.1016/j.corsci.2009.05.024>.
- [13] T. Durak, J. Depciuch, *Environ. Exp. Bot.* 169 (2020) 1-13. <https://doi.org/10.1016/j.envexpbot.2019.103915>.
- [14] C. Verma, A. Singh, P. Singh, K.Y. Rhee, A. Alfantazi, *Coord. Chem. Rev.* 515 (2024) 215966. <https://doi.org/10.1016/j.ccr.2024.215966>.
- [15] C. Verma, D.K. Verma, E.E. Ebenso, M.A. Quraishi, *Heteroat. Chem.* 29 (2018) 21437. <https://doi.org/10.1002/hc.21437>.
- [16] A. Carmona-Hernandez, M.C. Barreda-Serrano, H.A. Saldarriaga Noreña, R. López-Sesenes, J.G. González-Rodríguez, E. Mejía Sánchez, J.A. Ramírez-Cano, R. Orozco-Cruz, R. Galván-Martínez, *Molecules* 29 (2024) 5243. <https://doi.org/10.3390/molecules29225243>.
- [17] M. Dent, R. Fuchs-Godec, *FTB* 59 (2021) 413-421. <https://doi.org/10.17113/ftb.59.04.21.7026>.
- [18] M. Deyab, E. Guibal, *Sci. Rep.* 10 (2020) 4812. <https://doi.org/10.1038/s41598-020-61810-9>.
- [19] K. Žbulj, L. Hrnčević, G. Bilić, K. Simon, *Energies* 15 (2022) 3074. <https://doi.org/10.3390/en15093074>.
- [20] M. Mitrović, S. Apostolov, R. Fuchs-Godec, B. Salkunić, G. Vastag, M. Tomić, *PERIOD. POLYTECH-CHEM.* 68 (2024) 609-619. <https://doi.org/10.3311/PPch.37211>.
- [21] S. Vranjes, D. Zoric, *STES proceedings* (2018), 19. <https://doi.org/10.7251/SSN1811015V>.
- [22] R. Fuchs-Godec, *Coatings* 11 (2021) 971. <https://doi.org/10.3390/coatings11080971>.
- [23] D. Jedrejek, B. Lis, A. Rolnik, A. Stochmal, B. Olas, *Food Chem. Toxicol.* 126 (2019) 233-247. <https://doi.org/10.1016/j.fct.2019.02.017>.
- [24] K. Nuridullaeva, E. Karieva, R. Khalilov, *Pharm. Chem. J.* 57 (2023) 1298-1303. <https://doi.org/10.1007/s11094-024-03038-9>.
- [25] A. Zomorodian, R. Bagonyi, A. Al-Tabbaa, *J. Build. Eng.* 38 (2021) 102171. <https://doi.org/10.1016/j.jobbe.2021.102171>.

MILORAD TOMIĆ^{1,2}MARIJA MITROVIĆ¹REGINA FUCHS-GODEC³NEBOJŠA VASILJEVIĆ¹DRAGAN TOŠKOVIĆ¹MIOMIR PAVLOVIĆ^{1†}

¹University of East Sarajevo, Faculty of Technology Zvornik, Zvornik, Republic of Srpska, Bosnia and Herzegovina

²Engineering Academy of Serbia, Belgrade, Serbia

³University of Maribor, Faculty of Chemistry and Chemical Engineering, Maribor, Slovenia

NAUČNI RAD

ISPITIVANJE EKSTRAKTA KORENA MASLAČKA KAO ZELENOG INHIBITORA KOROZIJE ČELIKA U KISELOJ SREDINI

Cilj ovog rada je ispitivanje potencijala ekstrakta korena maslačka kao ekološki prihvatljivog inhibitora korozije čelika u kiseloj sredini. Ispitivano je inhibitorско dejstvo ekstrakta na dve vrste čelika TH-550 i TS-275. Efikasnost inhibicije korozije određena je praćenjem gubitka mase uzoraka čelika tokom 72 sata u četiri različita rastvora: 4% HCl bez inhibitora i 4% HCl sa 0,5; 1,0; i 1,5 g/L ekstrakta korena maslačka. Efikasnost inhibitora, izračunata na osnovu gubitka mase, kretala se u opsegu od 70% do 89%. SEM analiza površine uzoraka čelika nakon 24 sata u inhibiranom i neinhbiranom rastvoru ukazala je na formiranje ravnomernog zaštitnog filma na čeliku izloženom rastvoru sa inhibitorom, dok su uzorci u kontrolnom kiselom rastvoru pokazali značajne znake korozije. FTIR analizom određeno je da su C–H, C–O, C=O i O–H ključne funkcionalne grupe koje omogućavaju interakciju bioaktivnih komponenata prisutnih u ekstraktu sa čelikom i posledično formiranje zaštitnog sloja na površini metala. Rezultati dobijeni polarizacionim merenjima pokazali su da ekstrakt korena maslačka deluje kao anodna vrsta inhibitora korozije i da formirani zaštitni sloj pokriva do 88% površine čelika. Rezultati dobijeni na osnovu spektroskopije elektrohemijske impedanse, kao i rezultati polarizacionih merenja i praćenja gubitka mase, pokazali su da se efikasnost inhibicije ekstrakta korena maslačka povećava sa porastom njegove koncentracije.

Ključne reči: korozija, zeleni inhibitori, ekološki prihvatljiv, ekstrakt korena maslačka, elektrohemija.